

October 1975

New Techniques for Associating the Stages of Aquatic Insects

A. V. Provonsha

W P. McCafferty
Purdue University

Follow this and additional works at: <https://scholar.valpo.edu/tgle>



Part of the [Entomology Commons](#)

Recommended Citation

Provonsha, A. V. and McCafferty, W P. 1975. "New Techniques for Associating the Stages of Aquatic Insects," *The Great Lakes Entomologist*, vol 8 (3)

DOI: <https://doi.org/10.22543/0090-0222.1251>

Available at: <https://scholar.valpo.edu/tgle/vol8/iss3/3>

This Peer-Review Article is brought to you for free and open access by the Department of Biology at ValpoScholar. It has been accepted for inclusion in *The Great Lakes Entomologist* by an authorized administrator of ValpoScholar. For more information, please contact a ValpoScholar staff member at scholar@valpo.edu.

NEW TECHNIQUES FOR ASSOCIATING THE STAGES OF AQUATIC INSECTS¹

A. V. Provonsha and W. P. McCafferty²

The immature forms of many benthic insect species are presently either undescribed or unidentifiable. The result is that associations with corresponding adult forms are often necessary in order to confirm specific and sometimes generic identifications. Specific determination of aquatic stages of insects is prerequisite to adequately understanding the various aspects and implications of autecological specificity and the synecological dynamics of an aquatic system. Wiggins (1966), among others, has adequately pointed out the basic necessity of being able to discriminate between immature aquatic species.

Confronted with the problem then, of inadequate immature taxonomy, workers have devised various techniques for capturing adults and for rearing aquatic insects. In conjunction with a project dealing with the aquatic insect fauna of Indiana we have, over the past two years, refined many of these techniques and developed some new ones. Although increased efficiency has been our primary criteria for equipment design and usage, the field orientation of the work has made portability and durability additional important qualities we have considered.

It is common knowledge that many crepuscular and nocturnal insects can be collected by taking advantage of their responsiveness to artificial lights. Due to the excessive damage that mechanical light traps often impose on soft bodied aquatic insects, particularly when large collections are taken, it is usually preferable to set a light source against a pale background and to simply "pick" the specimens by hand. This is especially true for the Ephemeroptera. In the past, this has usually been accomplished by picking specimens from the immediate area around the light or from the light fixture itself. Usually a reflective white cloth or sheet is draped over makeshift props or suspensions next to the water. Such techniques are crude at best.

We have designed and used a light reflector unit (Fig. 1) which is compact, highly portable, easy to set up, and can be used in most places regardless of the contours of the terrain. It is constructed by slipping two 4' x 3/4" wooden dowels through loops sewn on either end of a 42" x 33" white cloth which has a 1' wide vinyl apron sewn on the bottom to catch any insects which may fall from the screen (Fig. 2). When in use, the reflector is held rigid by two 3' x 1/8" stainless steel spring wires slipped into holes drilled part way through the two wooden dowels at approximately 1" from the ends (Fig. 3). The legs, also constructed from 4' x 3/4" wooden dowels, are attached to the reflector with four large eye screws (Fig. 4), which will allow them to rotate in any position to comply with the shape of the ground and desired angle of the reflector. The two eye screws which are attached to the frame should be bent at 45 degree angles to allow the legs to fold flat against the frame. This allows the entire reflector to be rolled up for easy transport and storage. When not in use, the reflector can be kept in a cloth or tubular carrying case, similar to those used for fishing rods.

Although aquatic insects appear to be attracted to light sources to varying degrees depending on the wave length and intensity (Hollingsworth, 1961), we have experienced good results with a portable black light such as the night collecting unit sold by BioQuip or American Biological Supplies, used in conjunction with a gas lantern. A one foot piece of heavy wire (which can be cut from a clothes hanger) is attached with a screw to the middle of the upper dowel of the light reflector unit. The black light is hung from this wire which suspends it in front of the screen, thus increasing total light reflection.

Most insects can be killed and preserved immediately upon capture. The mayflies, however, pose a special problem. Since the majority of those which come to light are

¹Published with the approval of the Director of the Purdue University Agricultural Experiment Station as Journal Series No. 5474.

²Department of Entomology, Purdue University, West Lafayette, Indiana 47907.

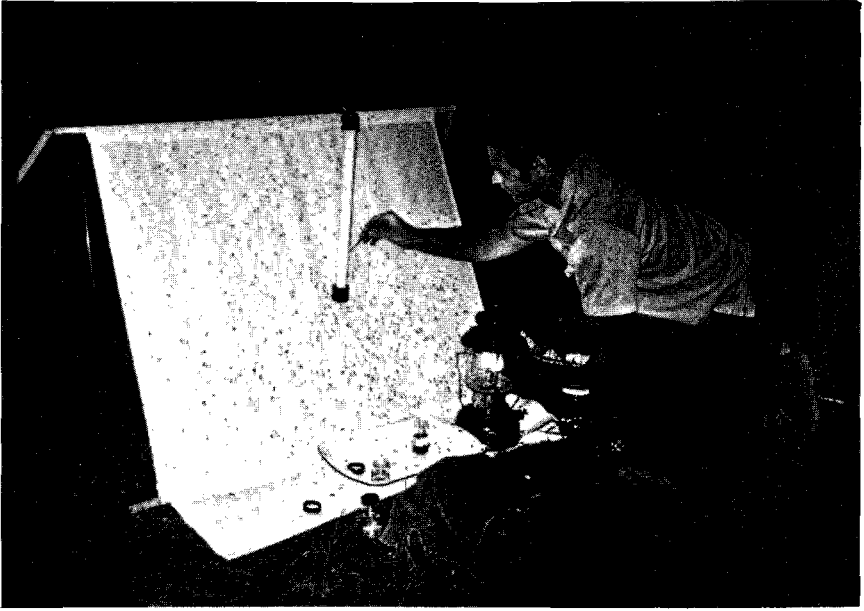
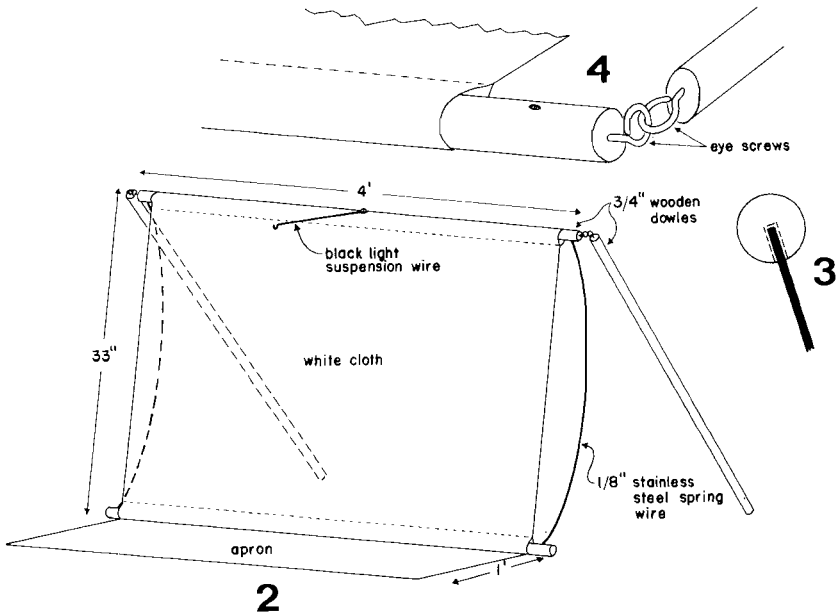

Fig. 1. Light reflector unit in operation.



Figs. 2-4. Diagram of light reflector unit assembly.

Fig. 2. Reflector unit assembly.

Fig. 3. Spring wire brace assembly.

Fig. 4. Leg assembly.

subimagos, they must be kept alive until they molt to the imago stage. This is also an explanation for the fact that light trap collecting is not efficient for mayflies. In the past, subimagos have been reared in paper bags, wire cages, and various types of small plastic and cardboard chambers which have met with only limited success.

We have found the most effective method for rearing large numbers of subimagos taken in the field is to place them in plastic crispers about the size of a shoe box (Fig. 5). By adding a small sliding door in the lid the worker can place specimens into the chamber without allowing others to escape in the process. A small section of screen may be substituted for part of the lid providing better ventilation which helps prevent over humidification in damp situations. Crumpled paper towels placed in the bottom provides good footing and when slightly dampened the problems of desiccation are greatly reduced.

We have found this procedure provides good visibility, large numbers of 'subs' can be collected, and most importantly since we are able to regulate the humidity the mortality rate can be kept to a minimum. However, these chambers must be kept out of the sun since plastic tends to intensify the internal temperature.

Capturing adults near the body of water from which they emerged can be helpful in making associations with their immature aquatic forms and in many cases increases substantially the probability of accurate identifications of these immatures. Obviously, such associations are only implied and are not positive proof of their relationship.

In order to obtain positive stage correlations it is necessary to rear individuals from larvae to adult. When possible, it is advantageous to maintain these larvae, which are often very sensitive to environmental changes, in their natural environment. Over the years various field rearing chambers have been developed, such as cylindrical wire cages (Needham, 1901), pillow cages (Needham, Traver and Hsu, 1931) and even modified plastic cups (Muller-Liebenau, 1969). We believe that the most important qualities to be incorporated into a field rearing chamber are good visibility, adequate footing and flight room for newly emerged winged forms, and easy access to specimens. Nevertheless, past

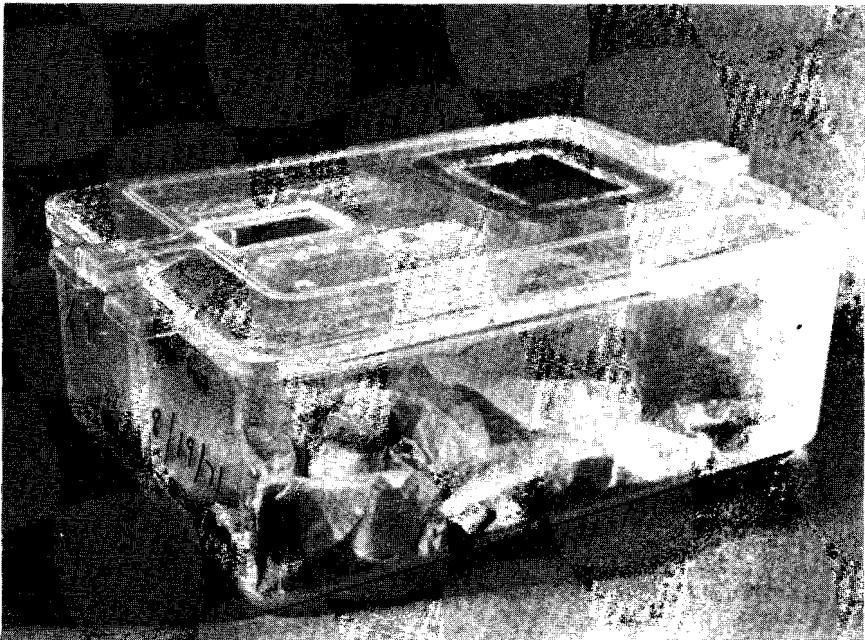

Fig. 5. Mayfly subimago rearing chamber.

designers have had to sacrifice some of the above mentioned qualities in their cages to maintain others.

We have developed a field rearing chamber (Fig. 6) which incorporates all of these qualities. The top, bottom, and sides are constructed with 1/16" plexiglass while the front and back are nylon netting. The back is glued to both sides for the entire length of the chamber, while the front is glued only along the bottom 2 1/2" and is attached along the remainder of the border with Velcro® at various points. This allows the front to be opened to varying degrees for easy access while at the same time preventing unwanted escape. These chambers may be constructed in any size desired, but the ones currently in use by us are 8" x 2" x 2". Chambers made any larger than this become bulky to transport if large numbers are needed, and they are not as practical for rearing individual specimens.

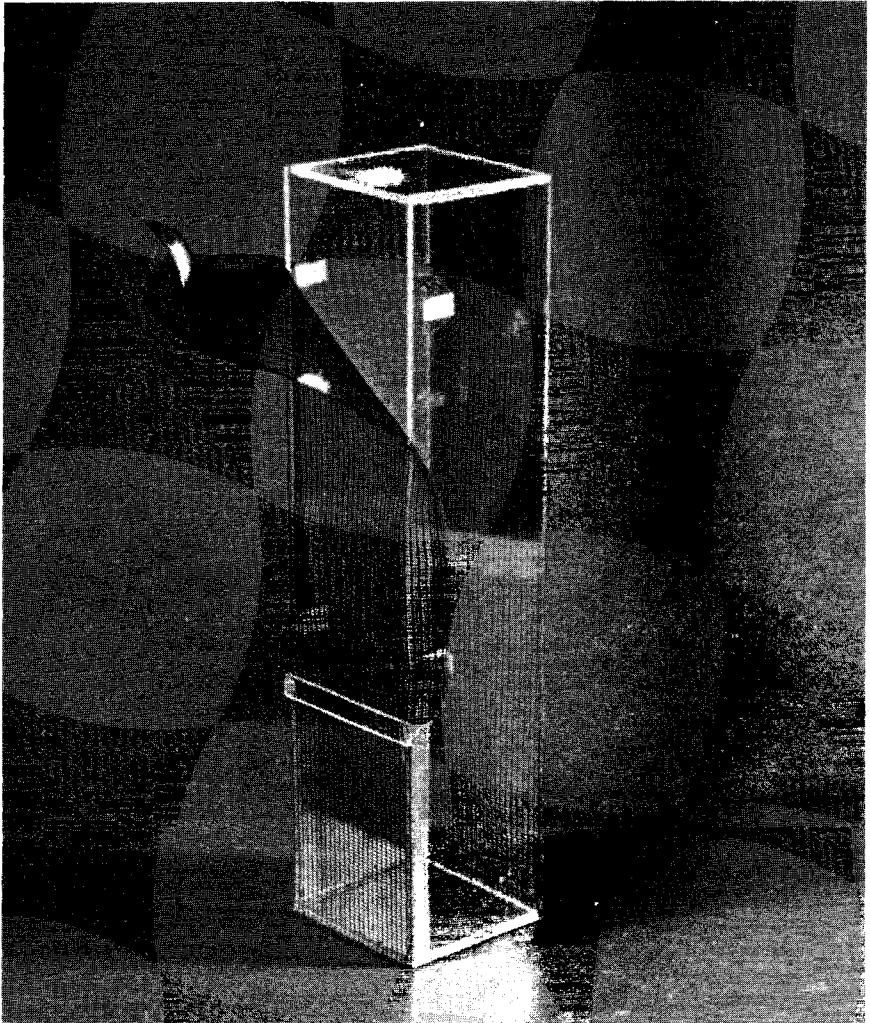

Fig. 6. Aquatic rearing chamber.

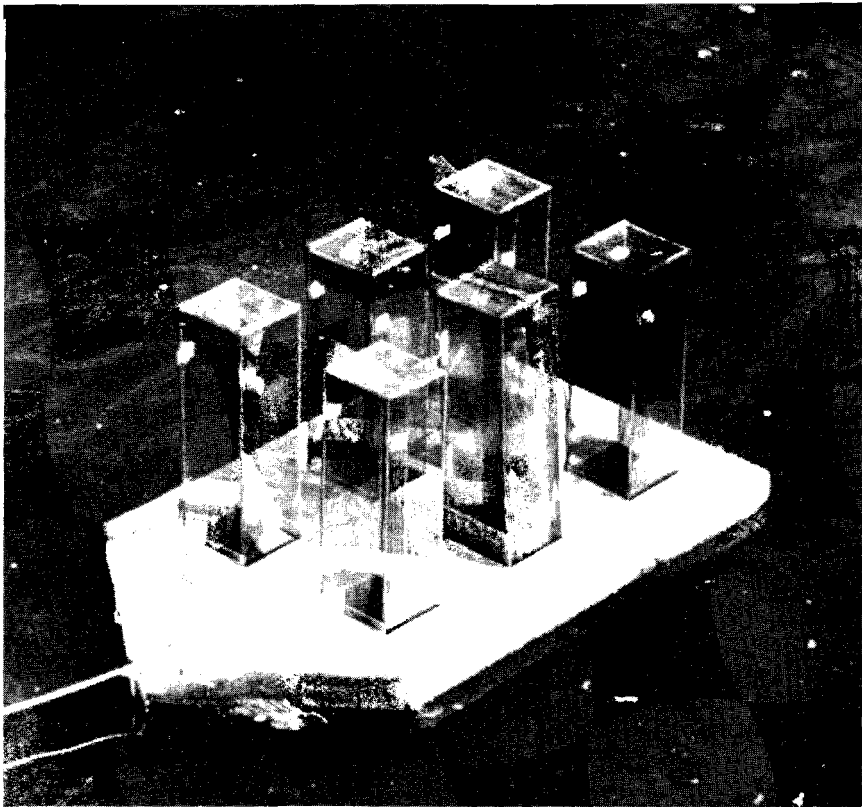

Fig. 7. Aquatic rearing chambers and float in use.

This chamber, like most others, is designed for use in the field and can be supported in a styrofoam float (Fig. 7) perpendicular to the float or at a slight angle to provide better footing for newly emerged individuals. If the float is cut in a triangle or boat shape, wire screening can be suspended from the front to detour any detritus from clogging the chambers.

LITERATURE CITED

- Hollingsworth, J. P. 1961. Relation of wavelength to insect response. p. 9-25 *In*: Response of insects to induced light. U.S. Dept. Agr. ARS 20-10. 66 p.
- Müller-Liebenau, I. 1969. Revision der europäischen Arten der Gattung *Baetis* Leach, 1815 (Insecta, Ephemeroptera). Eine Limnologische Schriftenreihe Heft 48/49.
- Needham, J. G. 1901. Ephemeridae. *In*: Aquatic insects of the Adirondacks. N.Y.S. Mus. Bull. 47:418-429.
- Needham, J. G., J. R. Traver, and Y. Hsu. 1935. The biology of mayflies. Comstock Pub. Co. Inc., Ithaca, N.Y. 759 p.
- Wiggins, G. B. 1969. The critical problem of systematics in stream ecology. p. 52-88, *In*: Cummins, K. W., C. A. Tryon, Jr., and R. T. Hartman (eds.), Organism-substrate relationships in streams. Spec. Publ. 4, Pymatuning Lab. Ecol., Univ. Pittsburgh. 145 p.